



PACKAGING AND SHIPPING

STONITE PRODUCTS SHIPPING INFORMATION

STONITE products are packed and shipped in two methods depending on the customer requests and final destination.

- Open crate – suitable for short distance shipping via freight trucks
- Closed crate – suitable for shipping in a container for long distance or over seas destinations

OPEN CRATE PACKAGING

Products placed on a standard wooden crate and wrapped with stretch film and tied with polyethylene straps including corner tabs. With this economy packaging STONITE products can be shipped on the truck to short to medium distances.

Most of the local and neighboring country shipments can be done with this method.

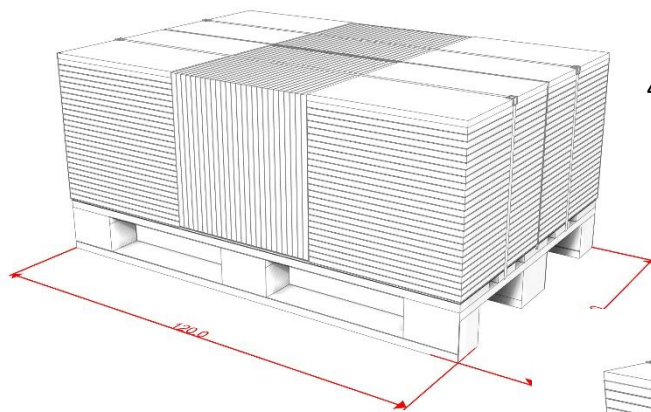

40 X 40 X 1.5 cm Product packaging

60 X 60 X 2 cm Product packaging

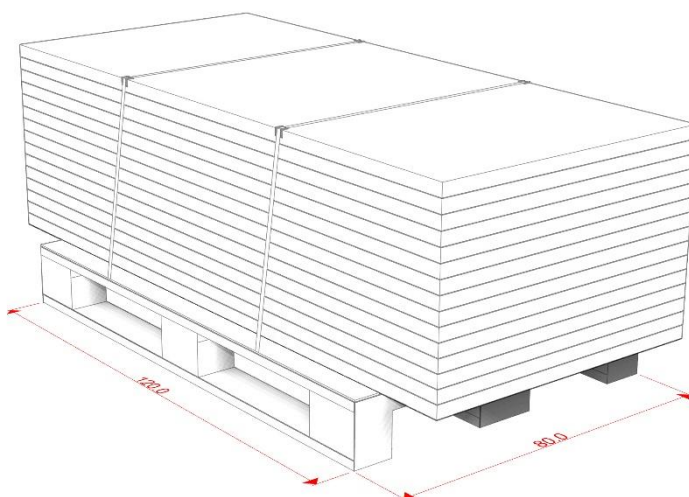
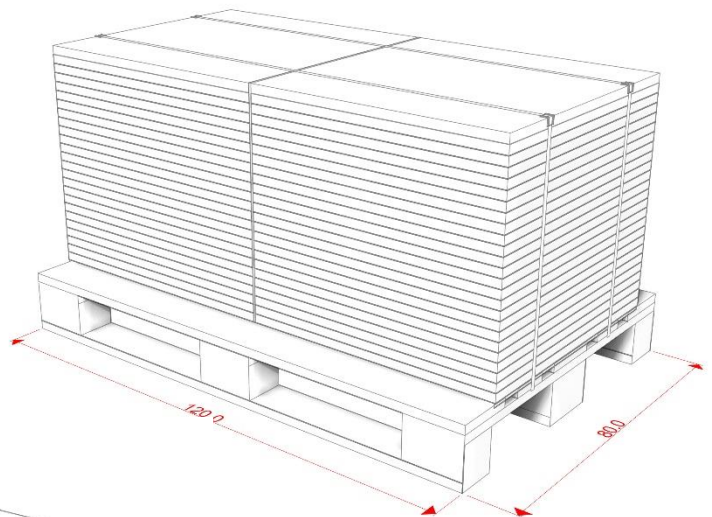

Slab Product packaging

CLOSED CRATE PACKAGING

Products are placed in closed crates padded with foam boards can be shipped inside containers or freight trucks to long distances or overseas locations safely.

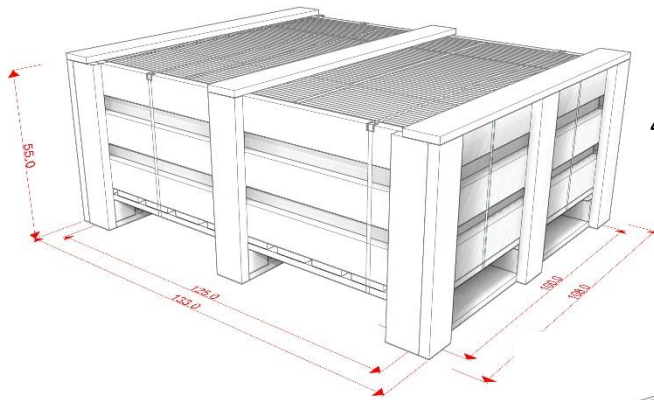

40 x 40 x 1.5 cm products closed crate packaging

60 x 60 x 2 cm products closed crate packaging

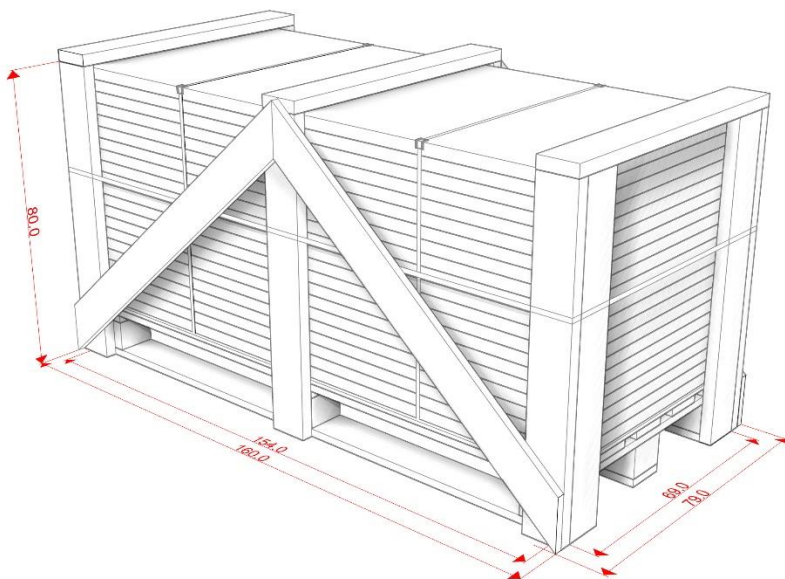
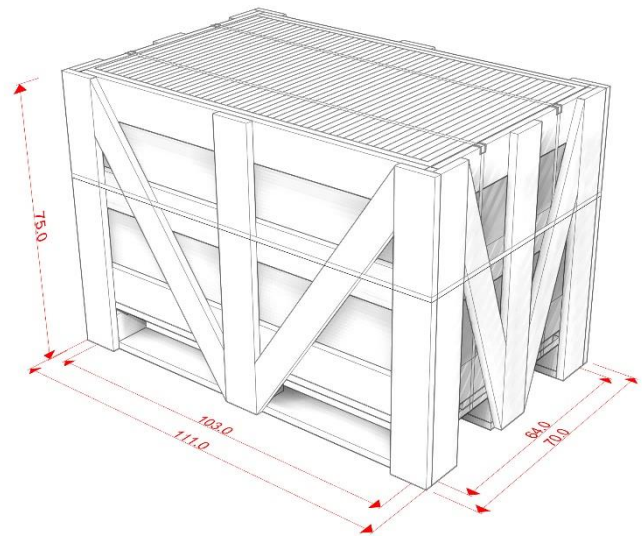

Slab products closed crate packaging

Shipping Container (Standard 20')

Product Type	m ² Products per crate	Count per crate	Crates per container	m ² Products per container	Weight per tile kg	Full Crate weight	Crate Size
40x40							
40X40X1.5	31,20	195	21,00	655	6,0	1210	133x108x55
60x60							
60X60X2.0	18,00	50	27,00	486	18,0	940	111x70x75
Levha							
153X68X3.0	21,84	21	14,00	306	78,0	1679	160x79x80
153X68X2.5	26,01	25	14,00	364	65,0	1666	160x79x80

Freight Truck (Standard 1360 x 245 cm)

Product Type	m ² Products per crate	Count per crate	Crates per truck	m ² Products per truck	Weight per tile kg	Full Crate weight	Crate Size
40x40							
40X40X1.5	25,60	160	26	665,60	6,0	990	120x80
60x60							
60X60X2.0	18,00	50	27	486,00	18,0	930	120x80
60X60X2.5	14,40	40	27	388,80	22,5	930	120x80
Levha							
153X68X3.0	15,60	15	21	328	78,0	1200	120x80
153X68X2.5	18,72	18	21	393	65,0	1200	120x80

* The information presented above contains approximate values and may vary due to order and required product thickness.

STONITE HQ

Şehit Mustafa Ruso Cad. No 54

Lefkoşa, KKTC via Mersin 10

Phone: +90 392 673 00 00

Fax: +90 392 673 00 99

Web: www.stonite.com.tr

E-mail: info@stonite.com.tr

STONITE Factory

Haspolat Sanayi Bölgesi

Lefkoşa, KKTC via Mersin 10

Phone: +90 392 233 56 78 - +90 392 233 56 76

Fax: +90 392 233 58 03

STONITE İstanbul Office

Büyükdere Caddesi, Gülbahar mahallesi

No:95 Kat:5 Daire: 17, Şişli/İstanbul, Türkiye

Phone: +90 212 230 90 30

Fac: +90 212 230 95 18